

NOVA 150 Glas Heavy Duty

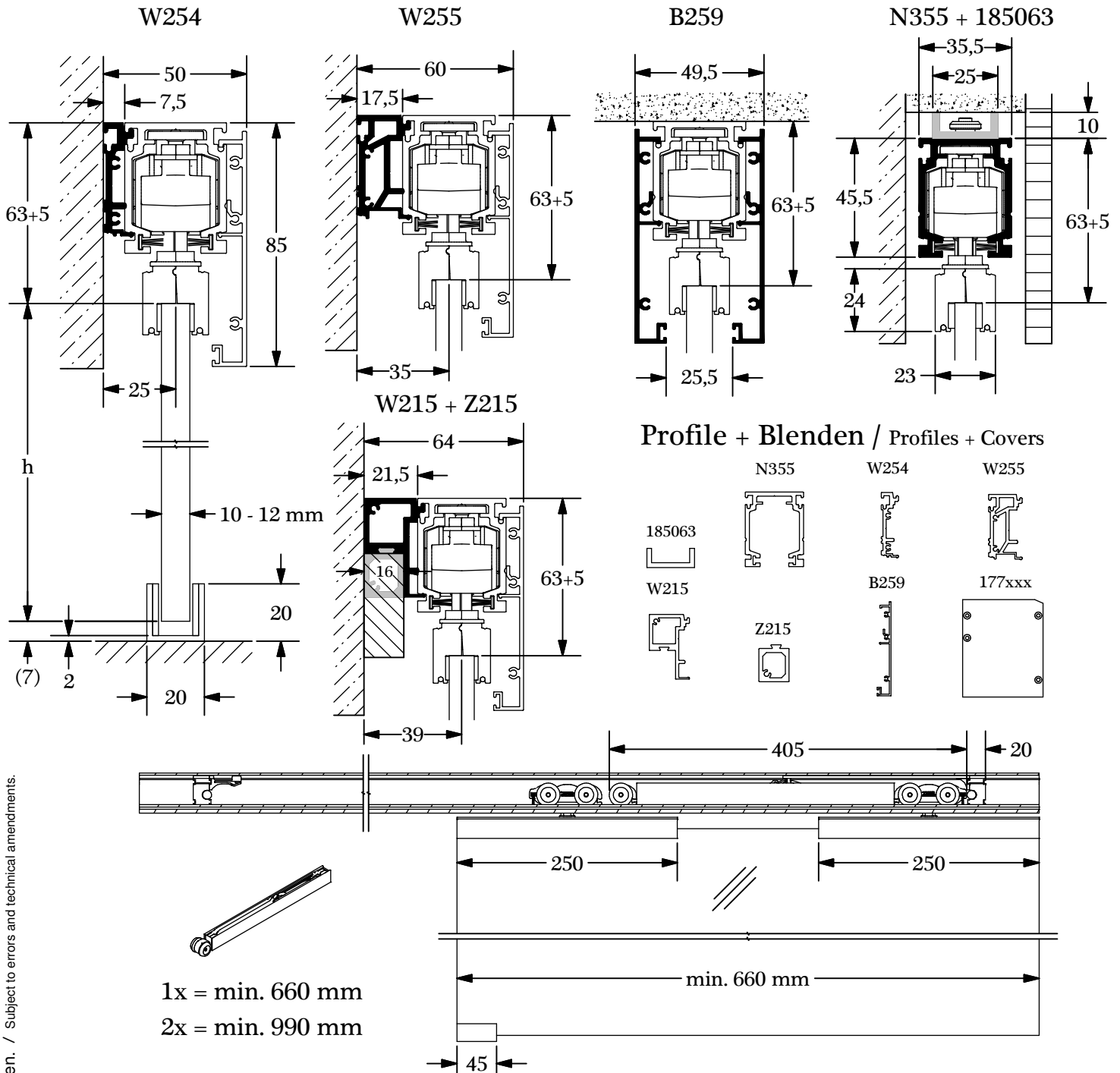

Irrtümer und technische Änderungen vorbehalten. / Subject to errors and technical amendments.

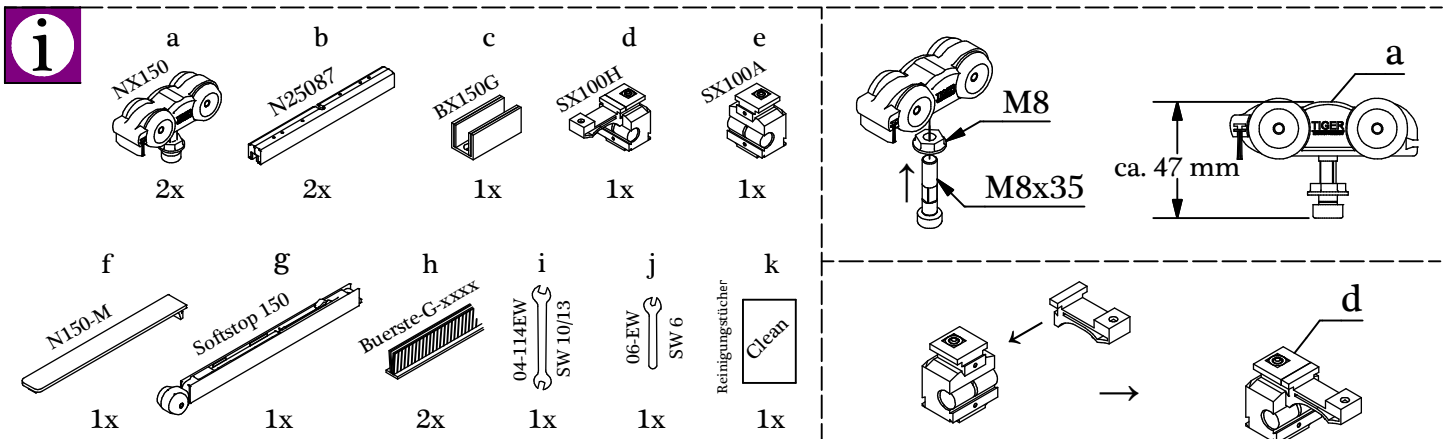

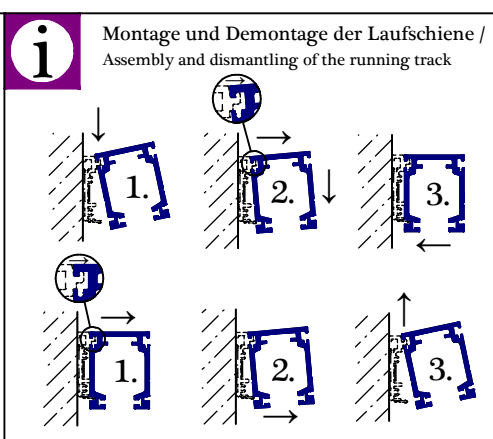
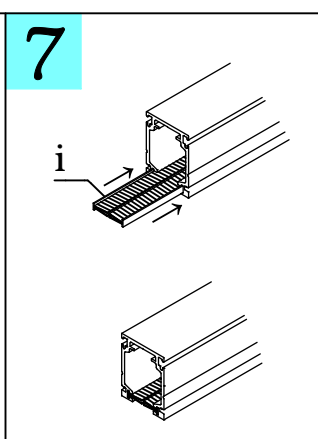
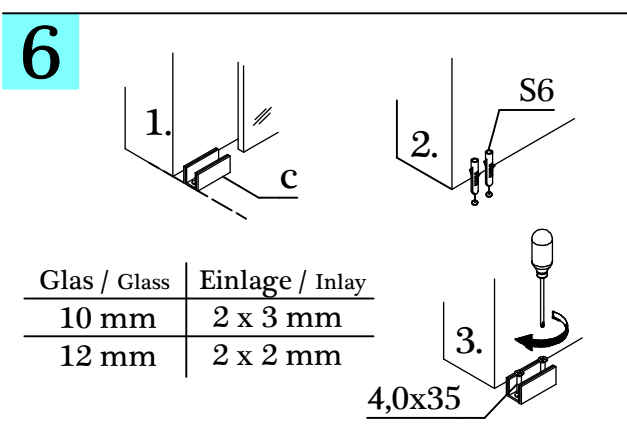
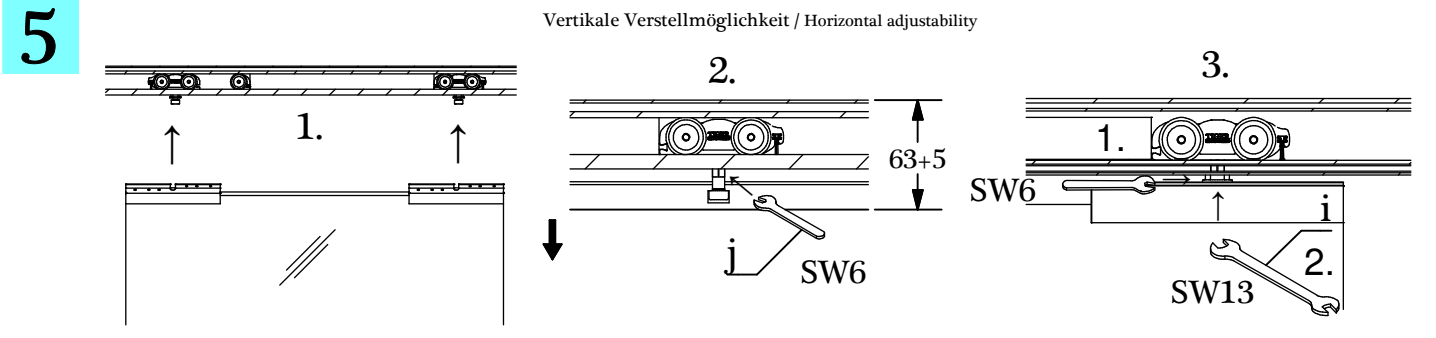
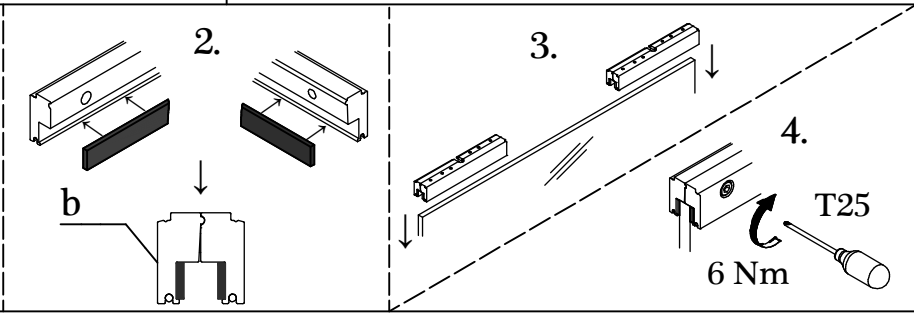
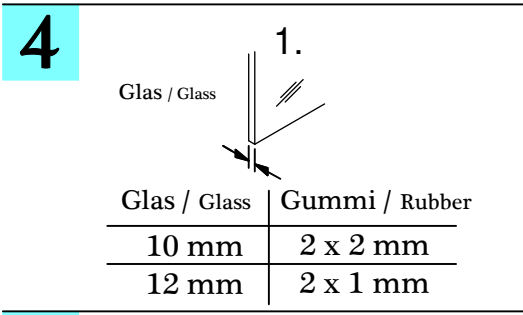
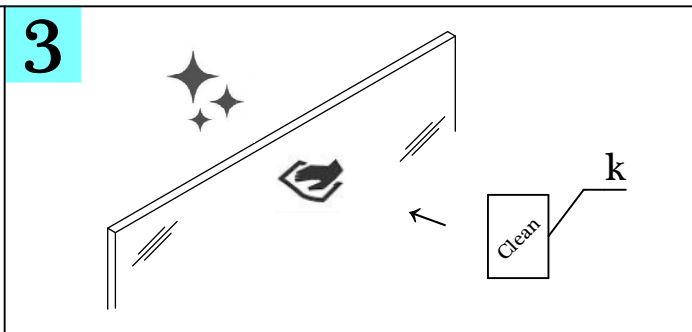
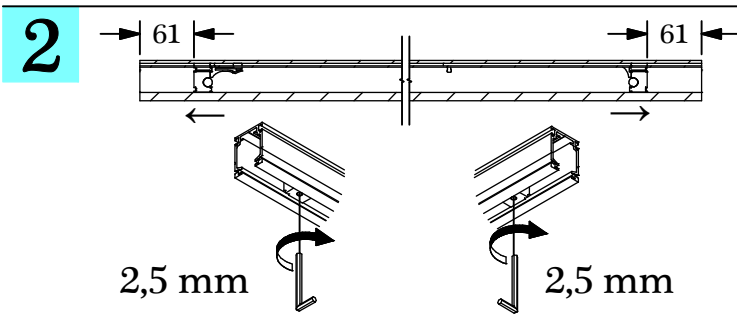
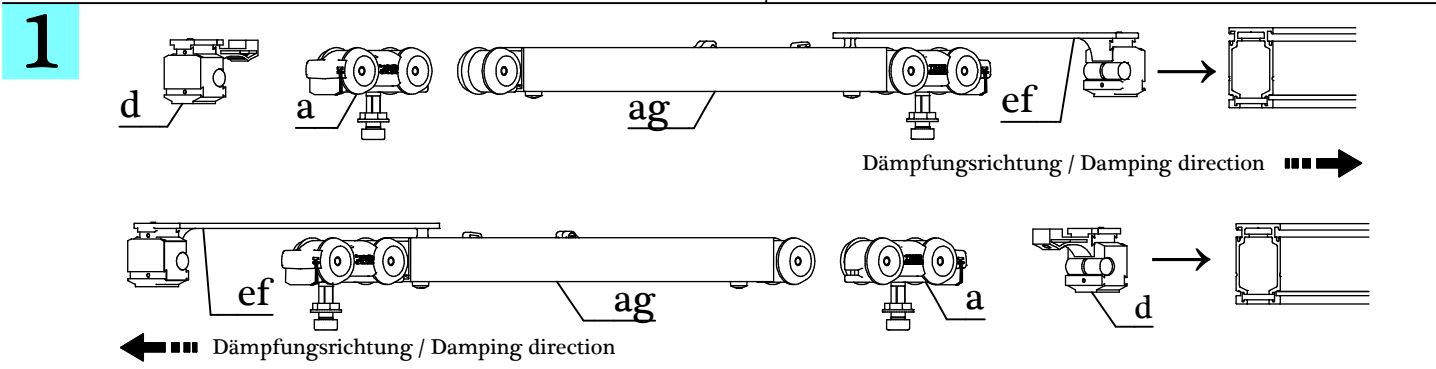
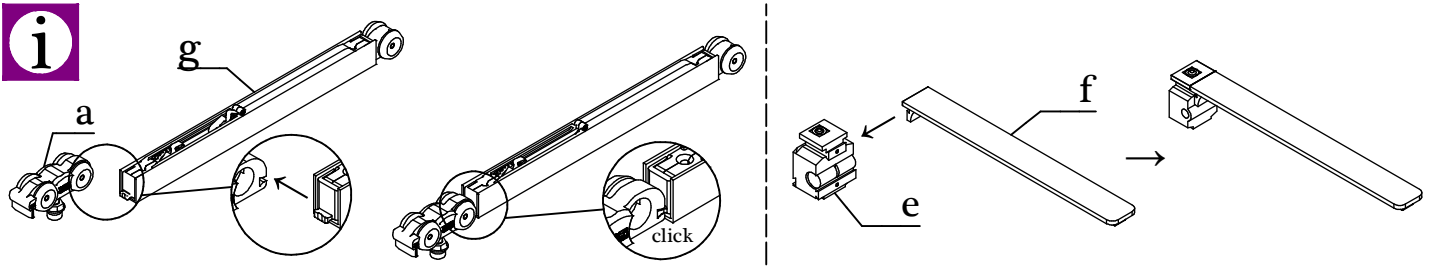

Irrtümer und technische Änderungen vorbehalten. / Subject to errors and technical amendments.