

ALU 40 NEO

For wooden doors up to 40 kg

- ✓ For lighter applications - carries wooden sliding elements up to 40 kg
- ✓ Slim form - narrow-profile aluminium tracks
- ✓ TIGER track advantage - Angular tread design guarantees centered and straightforward tracking and promotes self-cleaning
- ✓ Smooth running - precision ball bearings and quality nylon wheels
- ✓ Corrosion-resistant parts
- ✓ Easy installation with pre-assembled components
- ✓ Wall and ceiling installation possible
- ✓ Site-specific Covers





Boxed Set

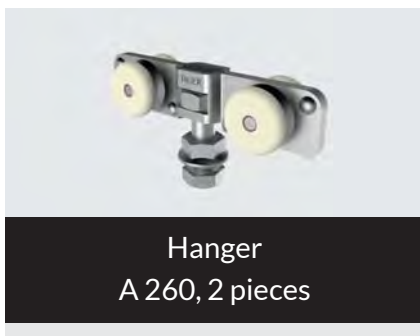

Tracks and Brackets

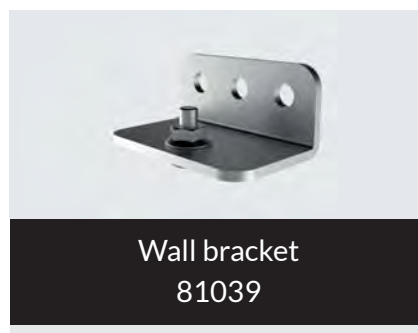

Complete Sets	Article Number
Boxed set + track, pre-drilled, 1650 mm, incl. 4 wall brackets	ALU40NEO-1650
Boxed set + track, pre-drilled, 2000 mm, incl. 4 wall brackets	ALU40NEO-2000

Boxed Sets/Tracks/Brackets	Article Number
Boxed set ALU 40 NEO	ALU40NEO-14
Track T260, aluminium, pre-drilled, 6000 mm	T260-033D6
Wall Brackets, 20 pieces	14 81039 VE20

Technical Notes

Maximum Door Weight	40 kg
Height	46 ±2 mm
Minimum Door Thickness	25 mm
Minimum Door Width	500 mm

Classification according to DIN EN 1527

Use Category	Durability	Door Weight	Fire Resistance	Safety	Corrosion Resistance	Security	Door Type	Initial Friction
-	6	1	0	-	0	-	1	3

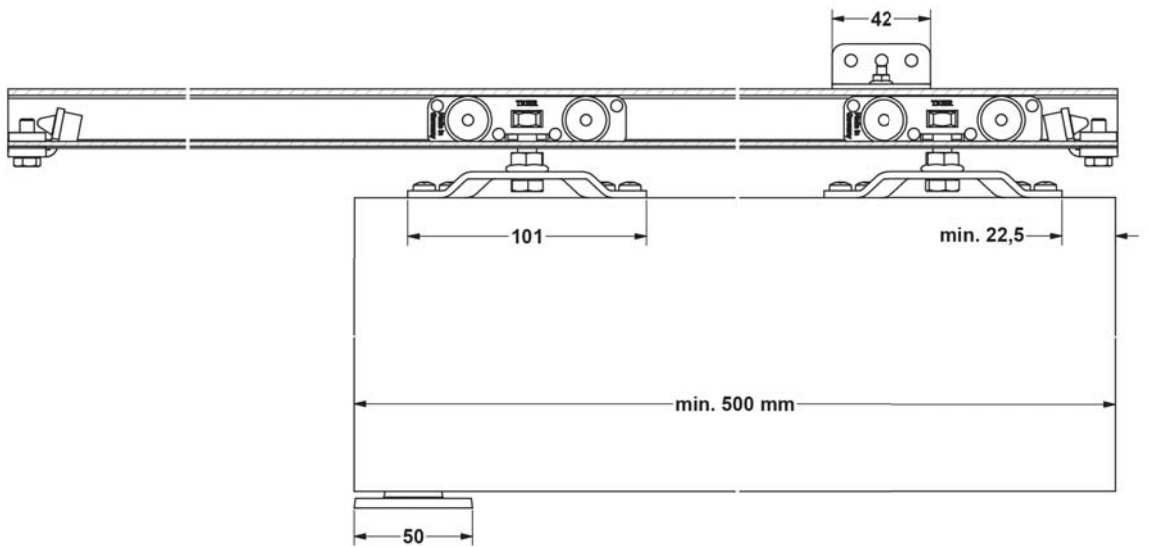
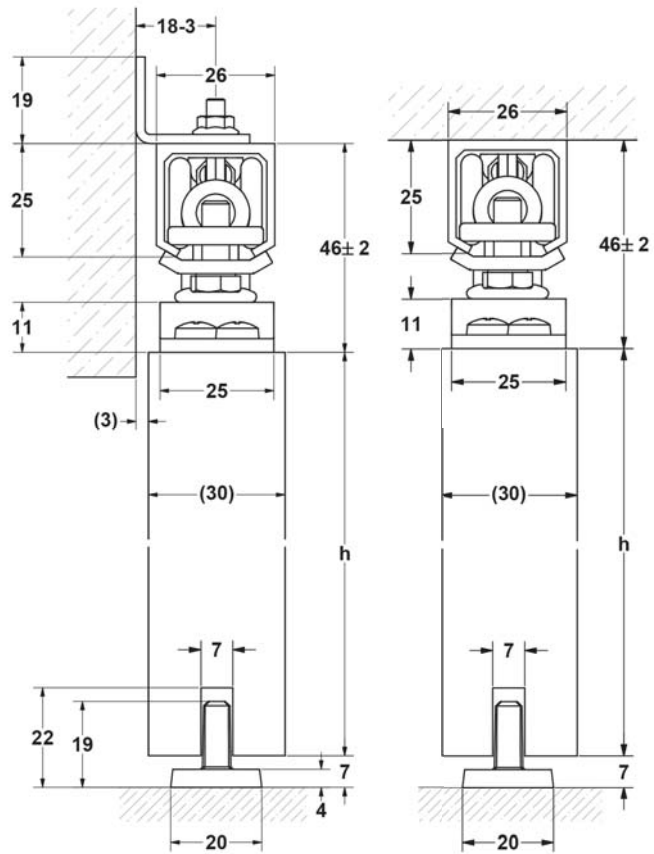

Technical Documents

Installation instructions, technical drawings and further information for this product can be downloaded at www.tiger.de. You will also find news and general information about all TIGER products.